



Name : \_\_\_\_\_

Part	Complete
1	

## Radius 10 Corners

When you see corners with a radius, the distance from the edges to the centre of the corner is equal to the radius.

In this case, R10, the distance from each edge to the centre of the corner is 10mm.

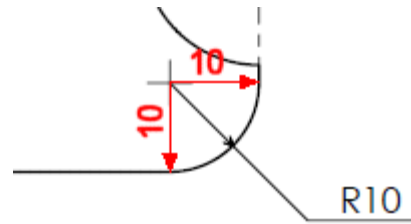

There are many ways in which you can mark these out.

---

## The Big Hole

### Method 1

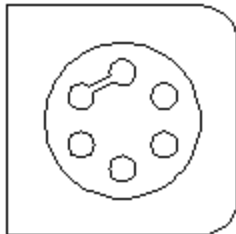

Drill a number of  $\text{Ø}7$  holes inside the big circle. Use a Junior Hacksaw to cut between the holes. Use a half-round file to complete the hole.

This method is quicker but there is a lot of filing.

### Method 2

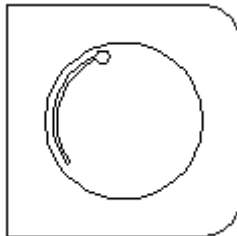

Drill a small hole, (about  $\text{Ø}3$ ), and use a Piercing Saw to cut close to the line. Use a half-round file to finish the hole.

This method requires less filing but the blades of a Piercing Saw are very delicate and are easy to break. Patience is required with this method.

---

## The Semi-Circles

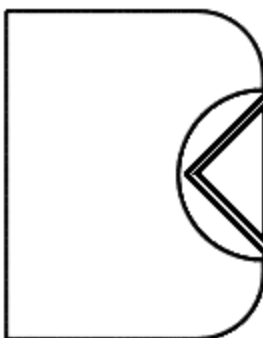

Method 1 : The same principle as Method 1 for the big hole.

Method 2 : Use a Hacksaw to cut a 'V' out of the semi-circle, then use a half-round file to complete the semi-circular hole.

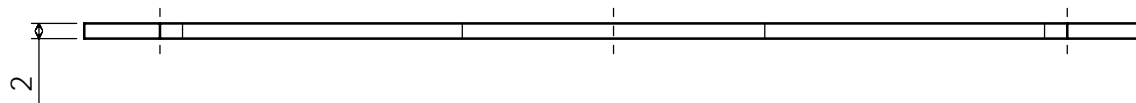
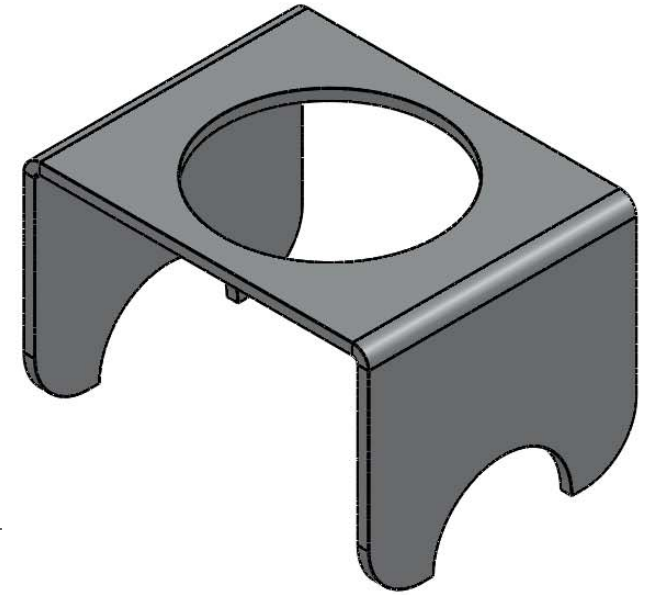
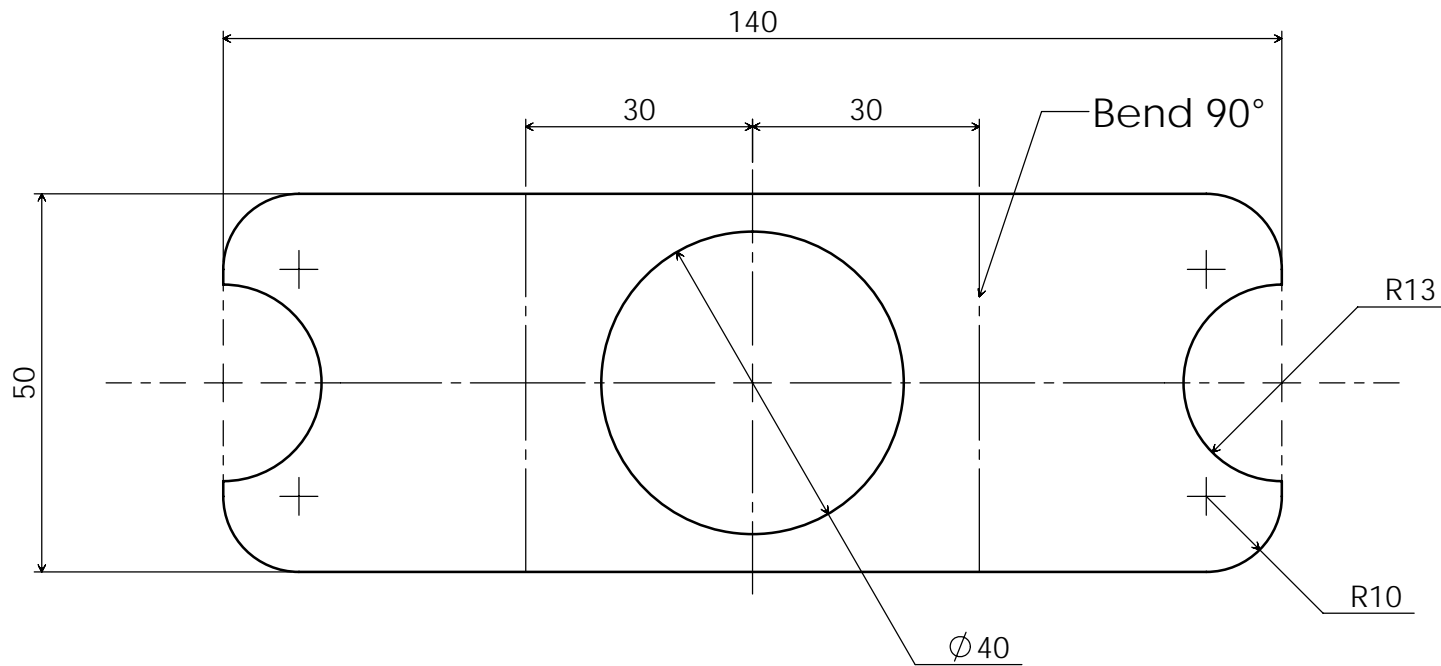

Egg Cup Holder 2	JC
PracticalStudent.com	
Part Number : 1	
Part Name : Egg Cup Holder	
Material : Aluminium	A4
	13/10/13
Required : 1	Drawing 1 of 1

Before Starting

Tools for Marking Out :

Tools for Manufacturing :

Skill I am going to concentrate on :

After completion

Marking Accuracy	Poor	Medium	Good
Hacksawing & Filing Quality	Poor	Medium	Good
Surface Finish	Poor	Medium	Good

What did I do well :

What do I need to improve on :